

# Poseidon LT - 100

Manual

English



Gebrüder Boley GmbH & Co. KG  
Julius-Hölder-Str. 32 - D-70597 Stuttgart  
Tel. +49-(0)711-13271-0 - Fax. +49-(0)711-13271-90  
info@boley.de - www.boley.de

# Table of Contents

Page	Contents
1	Table of Contents
2	Installation of the Device
3	Service Unit (Filter)
4 + 5	Description of the Parts
6	Commissioning
7 + 8	Select Language, Set Date and Time.
9 + 10	Test a Watch for Tightness
11	Results - Display
12	Functions of the Programmed Tests P1,P2,P3,P4,P5
13	Functions of the Programmed Tests P6,P7,P8,P9,
14	Functions of the Programmed Tests P10,P11,P12
15	Changing of Programs
16	Change Program Name
17	Edit Measurement Record Head
18	Printer Configuration idp 460 + CBM 910 + CBM 910 II
19	Printer Configuration idp 562 + idp 3535
20 + 21	Adjustment of the Setting Ring
22	Functioning of the Tightness Test Under Vacuum
23	Functioning of the Tightness Test Under Pressure
24	How to open the Poseidon
25	Poseidon is now open like a flower
26	General Information

## Installation of the Device

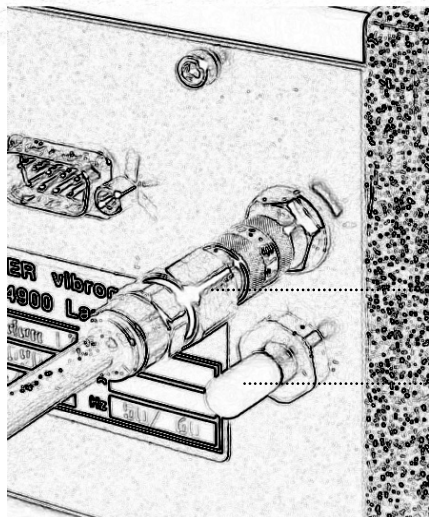
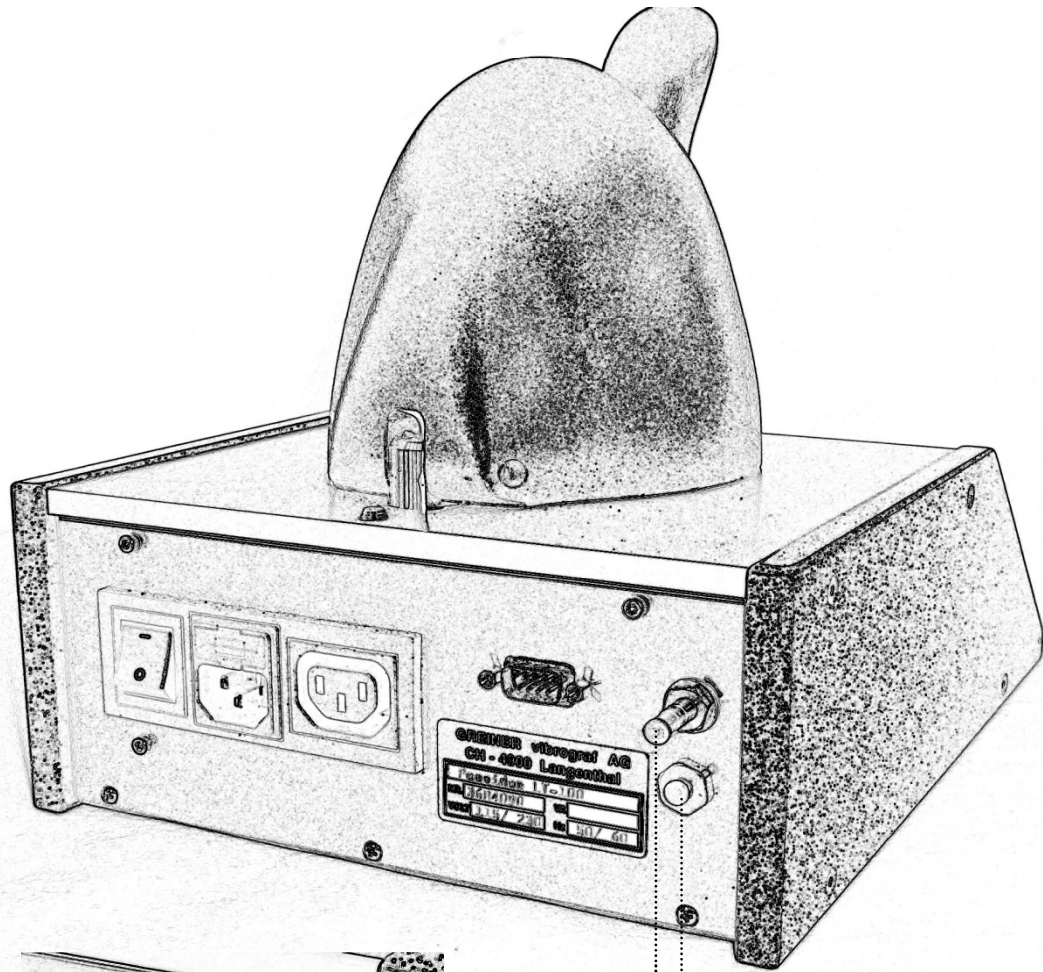

Remove protective plug  
and attach fast-coupling.

If there is a plastic  
protection, remove it  
and install the included  
air release filter.  
If there is a brass filter,  
leave it there.

**Furring caused by humidity (condensation) and dirt (dust particles) impair the function of the valves of the Poseidon LT-100.**

**Therefore we recommend that your compressor is provided with a maintenance unit in order to exclude damage to the equipment.**

**Should arise damage to the Poseidon LT-100 by neglect of this recommendation, we reject each guarantee for this.**

**Following maintenance unit can be furnished by us:**



**Maintenance unit consist of:**

- compressed air filter
- high level filter with contamination indicator
- connection block
- attaching bracket
- semiautomatic drainage
- air filter element 5um
- air filter element 0.01 um
- 2 fast clutches
- hose for connection with compressor

# Description of the Parts

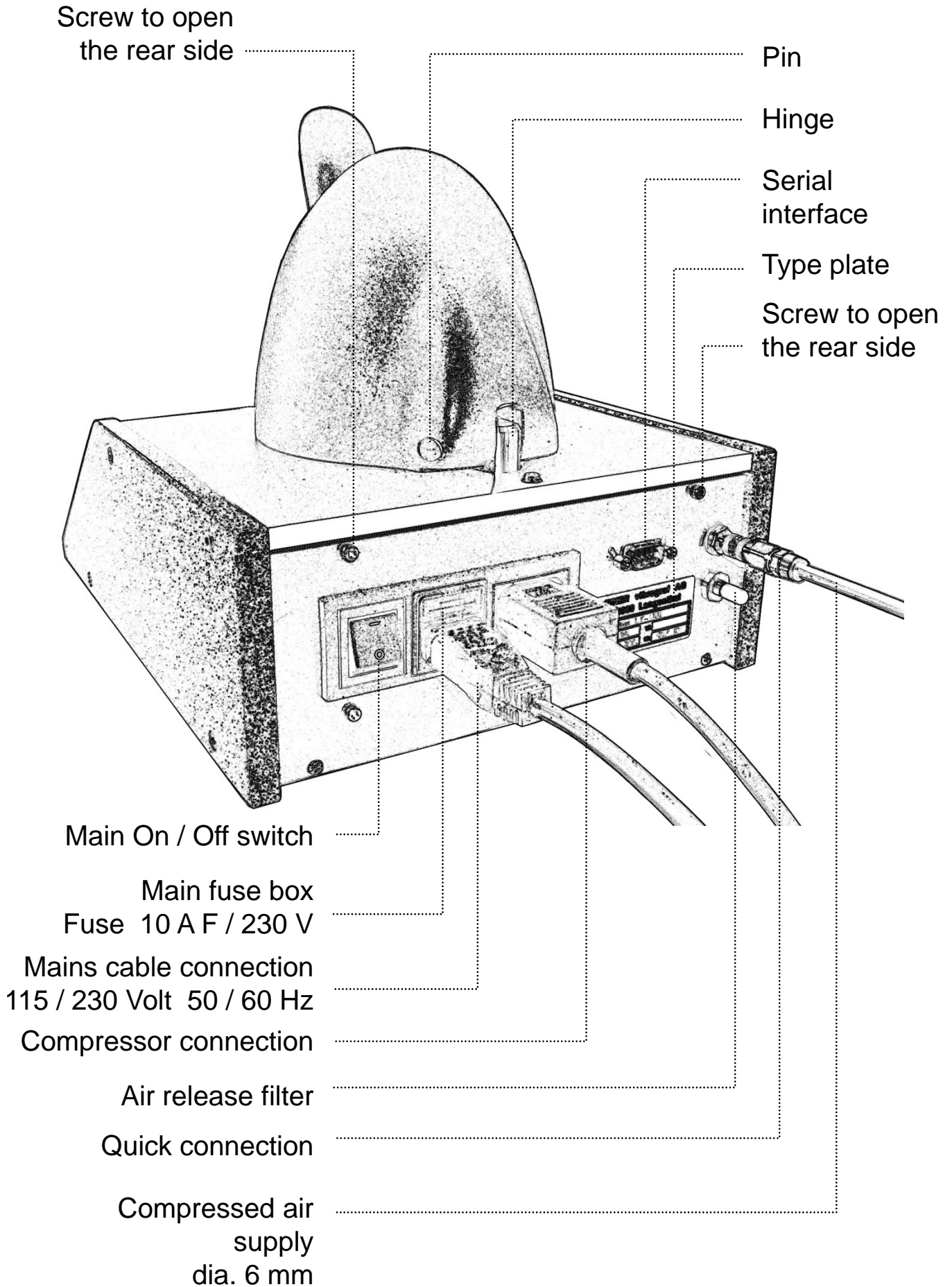

# Description of the Parts

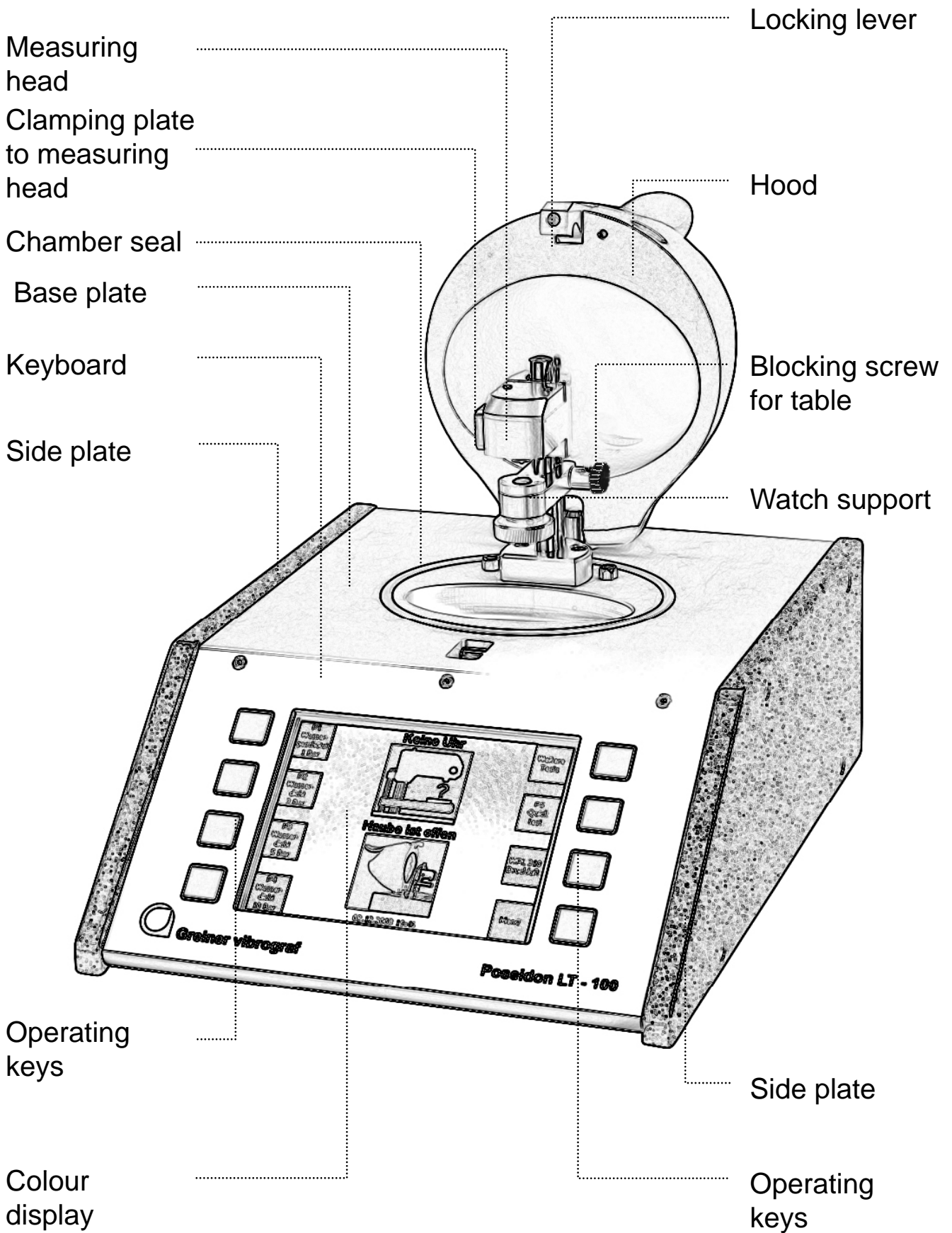

## Bring into Use

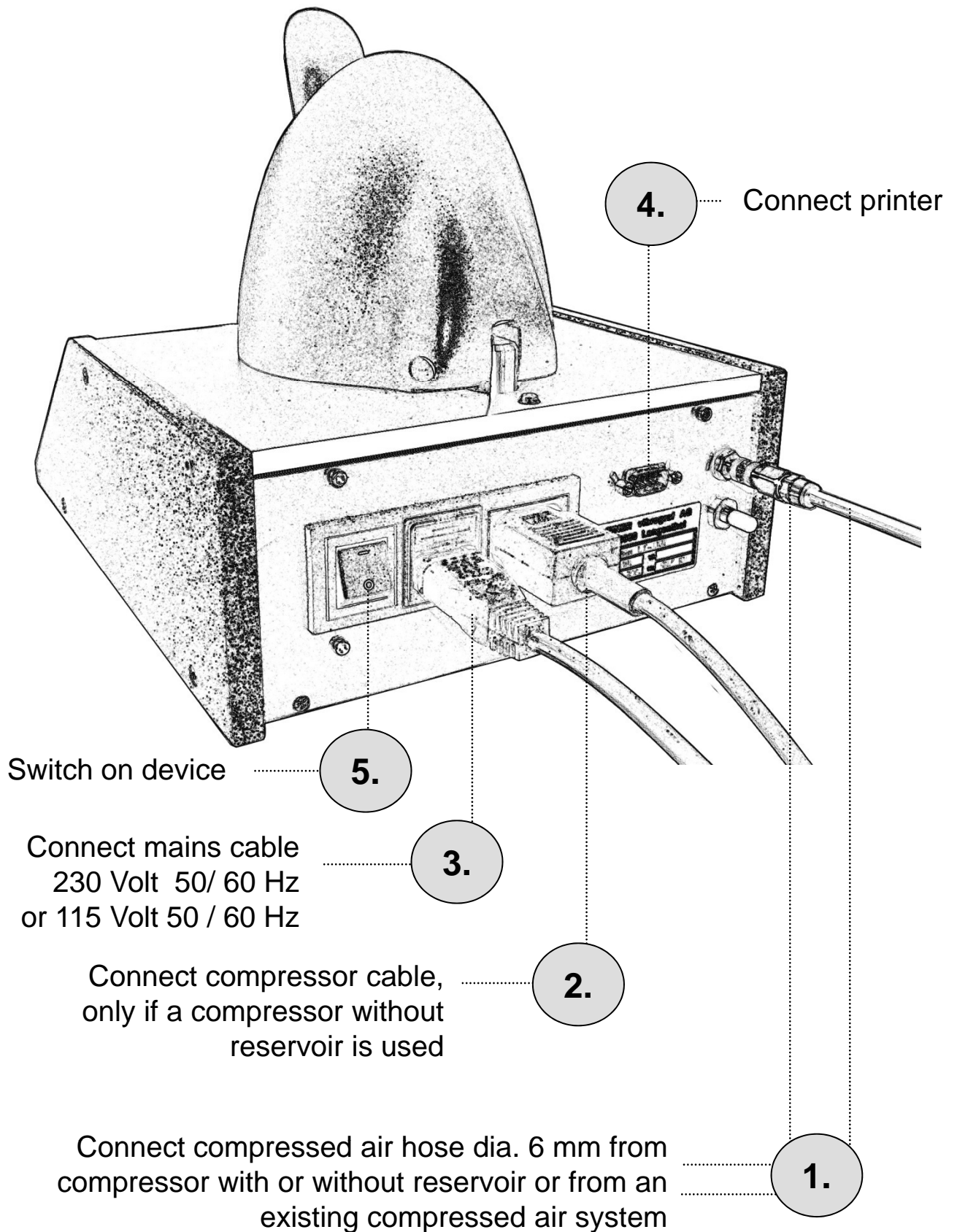



# Select Language - Set Date and Time

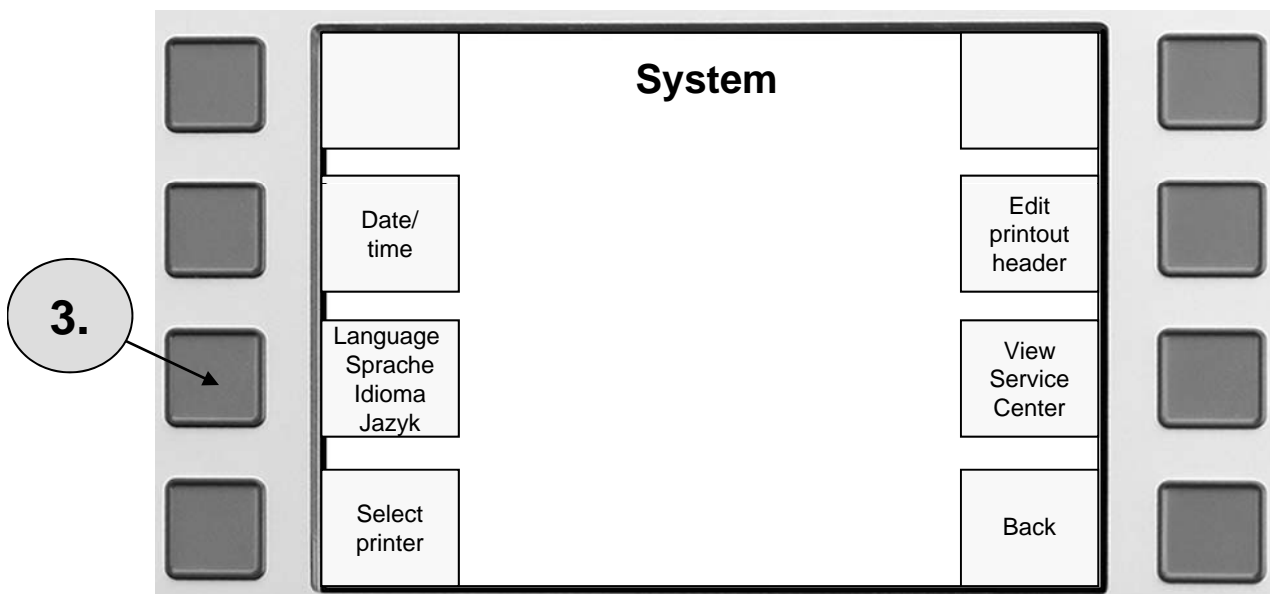
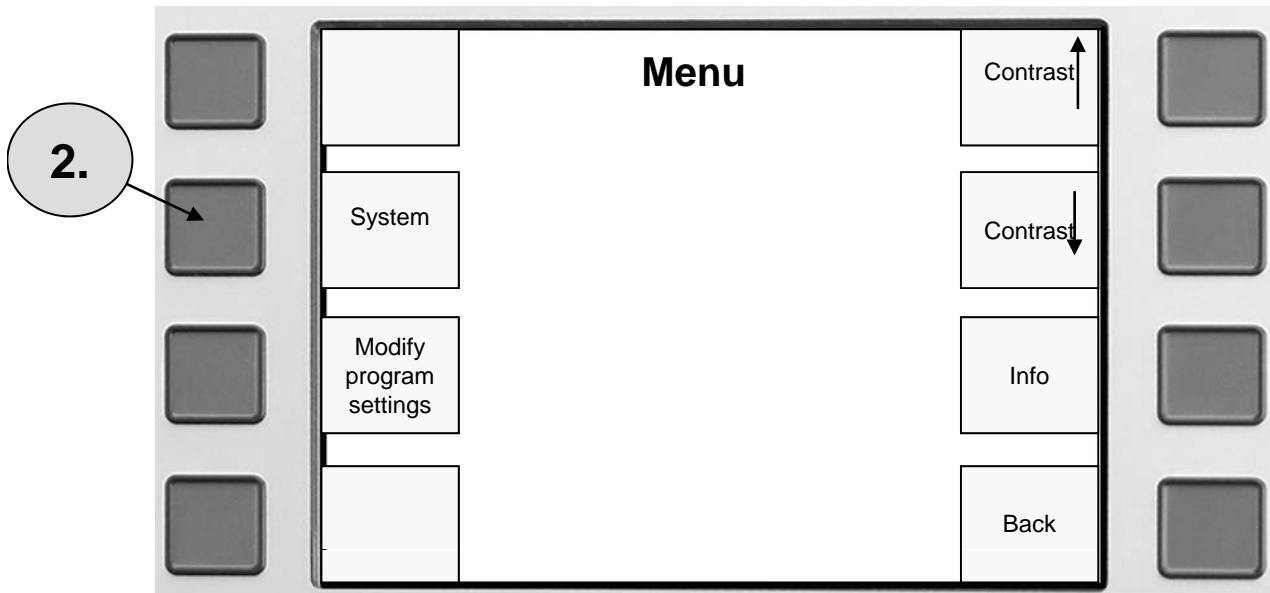
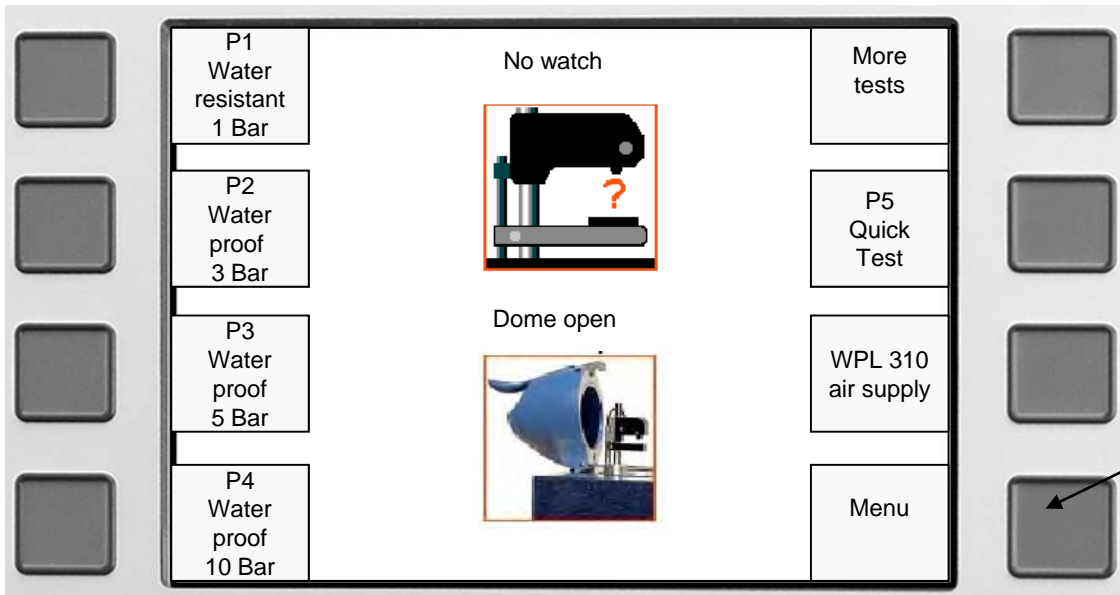



# Select Language - Set Date and Time

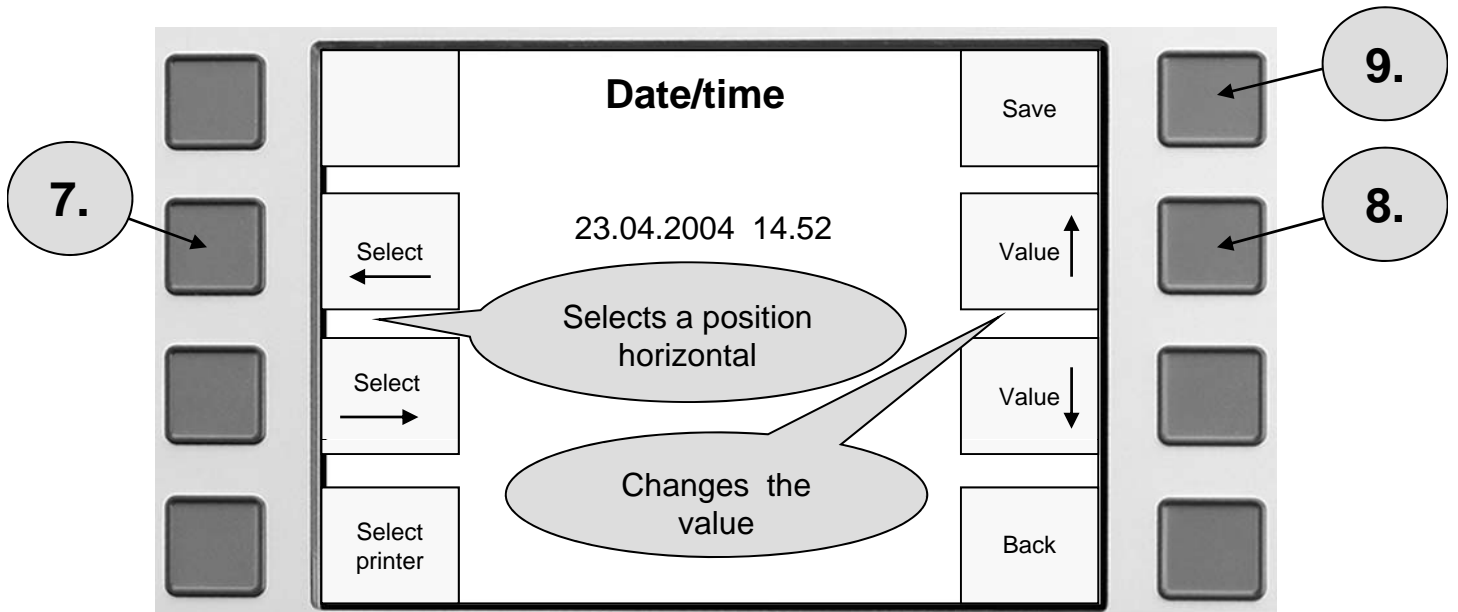
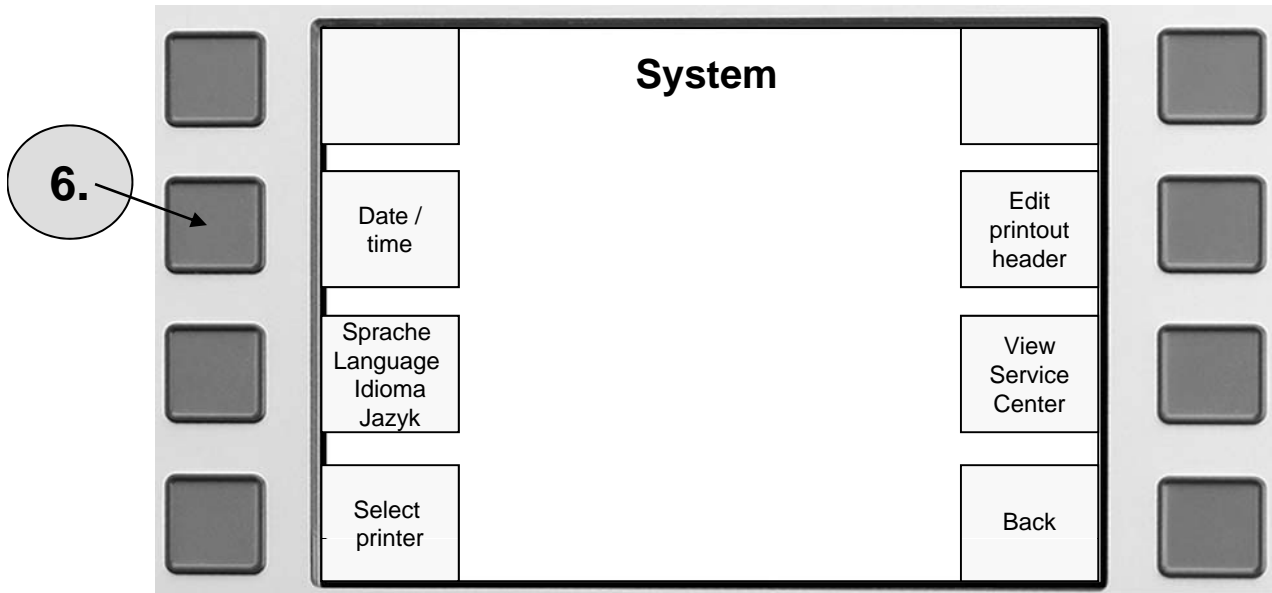
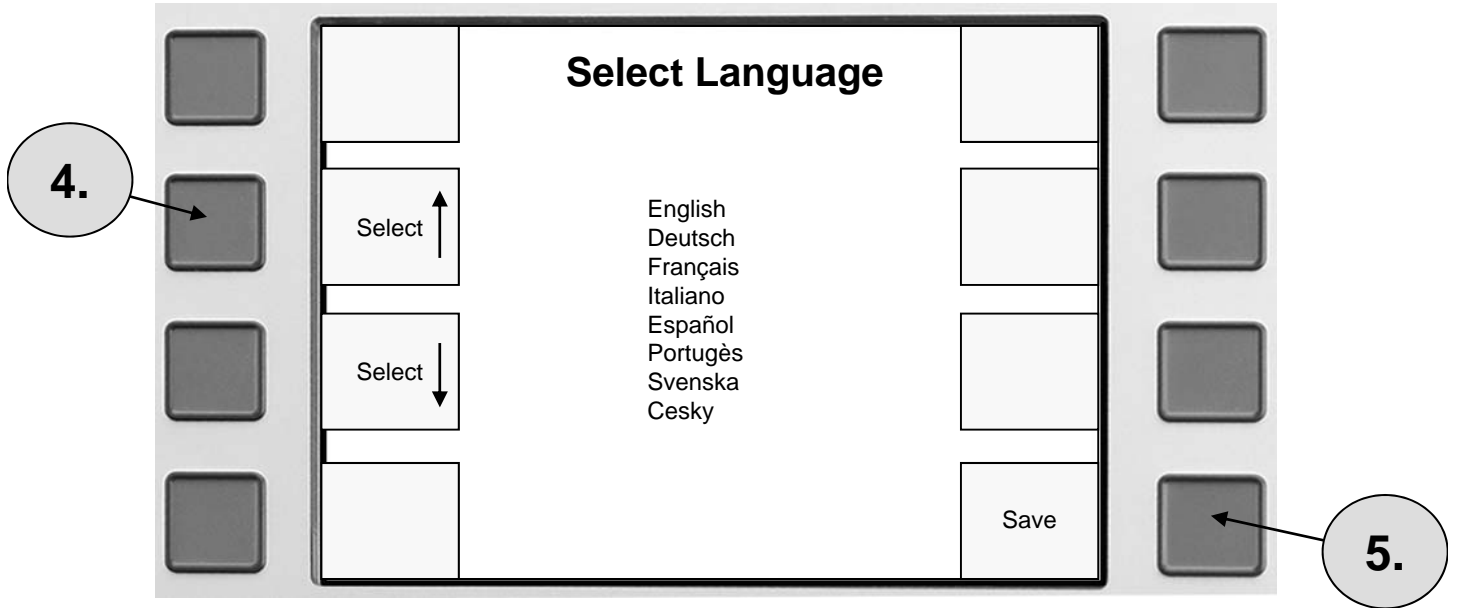

## Test a Watch for Tightness

1. Lay the watch on the table rest as shown in the picture.
2. Move with the measuring head by pressing the measuring head downwards onto the watch.

Press together the plate with the measuring head to move up or down.

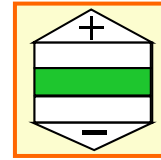
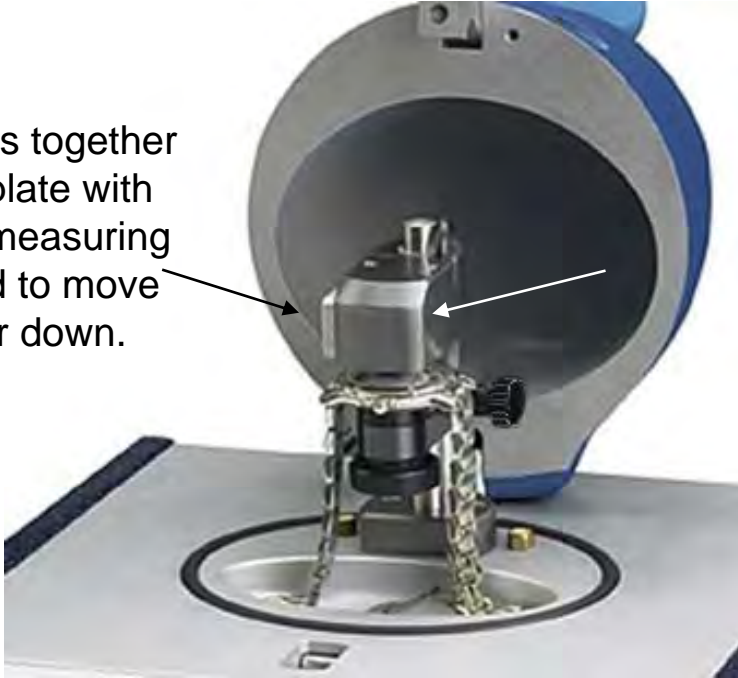

This indication appears on the display.

If one of the following indications appears,

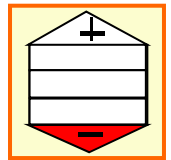
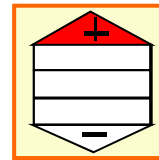
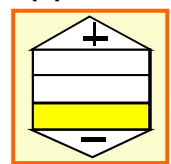
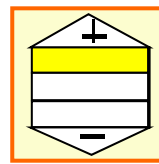

see on page 20 + 21.

### Information:

For small and very hard watches, use the small watch rest.

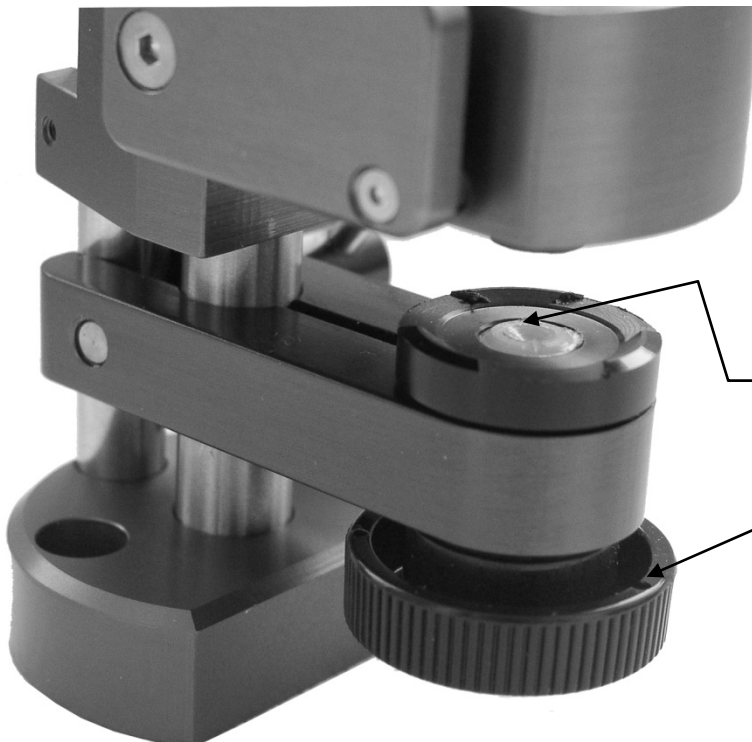

The small watch rest can be moved upwards by turning the screw to the stop in the clockwise direction.

# Test a Watch for Tightness

1. Select a test ( P1 , P2 , P3, P4 ), (Quick Test) or (more tests). See Pages 12, 13, 14.
2. Close the hood. The test will be started automatically.

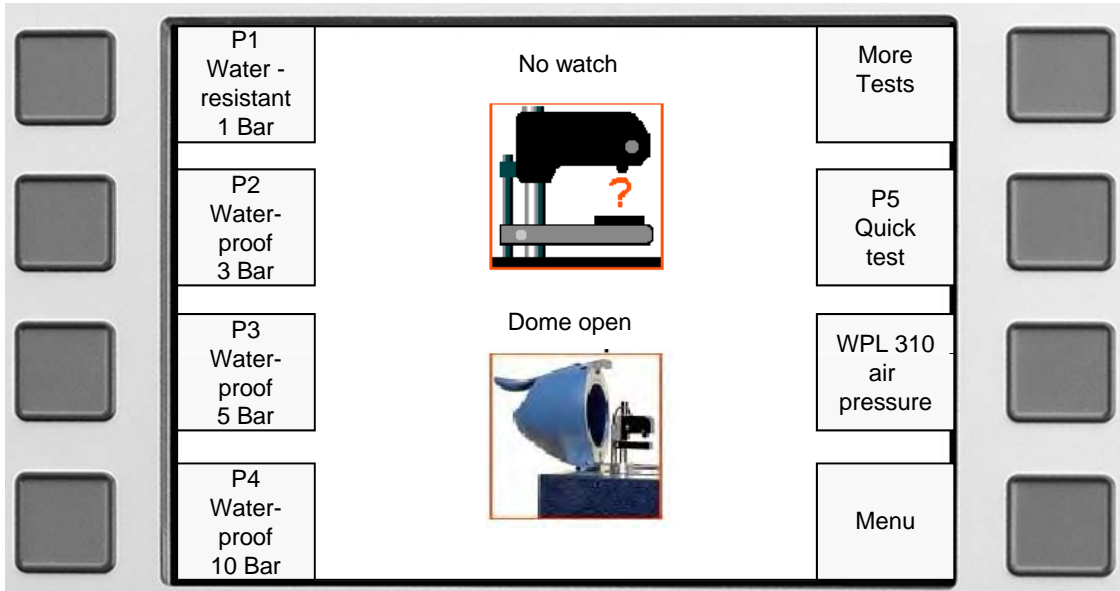

During the test you can choose to see the results as values or graphically

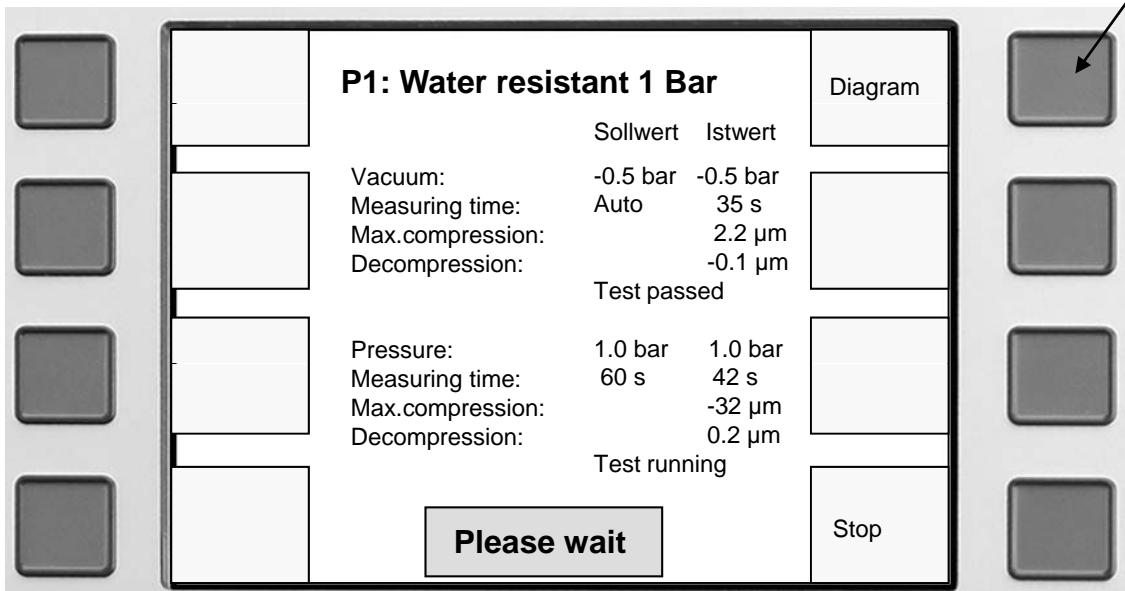

Press the Diagram key if you want to see the measured values graphically.

# Display of Results

Example

Display of the measured values as graphics

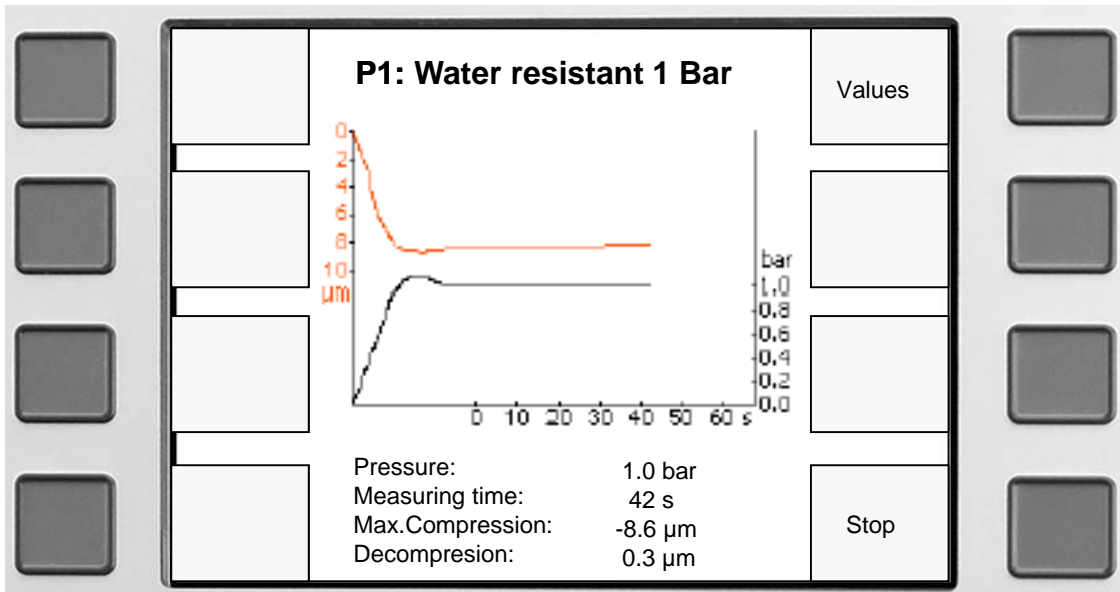

Display of the result with a water proof watch.

**P1: Water resistant 1 Bar**

Values

Diagram

Print certificate

Back

Test passed

No watch

Dome open

The screen displays a large green box with the text 'Test passed'. Below this, there are two small images: 'No watch' (a black watch on a stand with a red question mark) and 'Dome open' (a blue dome-shaped component on a stand). On the right side, there are four buttons: 'Values', 'Diagram', 'Print certificate', and 'Back'. The title 'P1: Water resistant 1 Bar' is at the top.

Display of the Result with a leaking watch.

**P1: Water resistant 1 Bar**

Values

Diagram

Print certificate

Back

Test failed

No Watch

Dome open

The screen displays a large red box with the text 'Test failed'. Below this, there are two small images: 'No Watch' (a black watch on a stand with a red question mark) and 'Dome open' (a blue dome-shaped component on a stand). On the right side, there are four buttons: 'Values', 'Diagram', 'Print certificate', and 'Back'. The title 'P1: Water resistant 1 Bar' is at the top.

## Functions of the Programmed Tests P1, P2, P3, P4 and ( Quick Test )

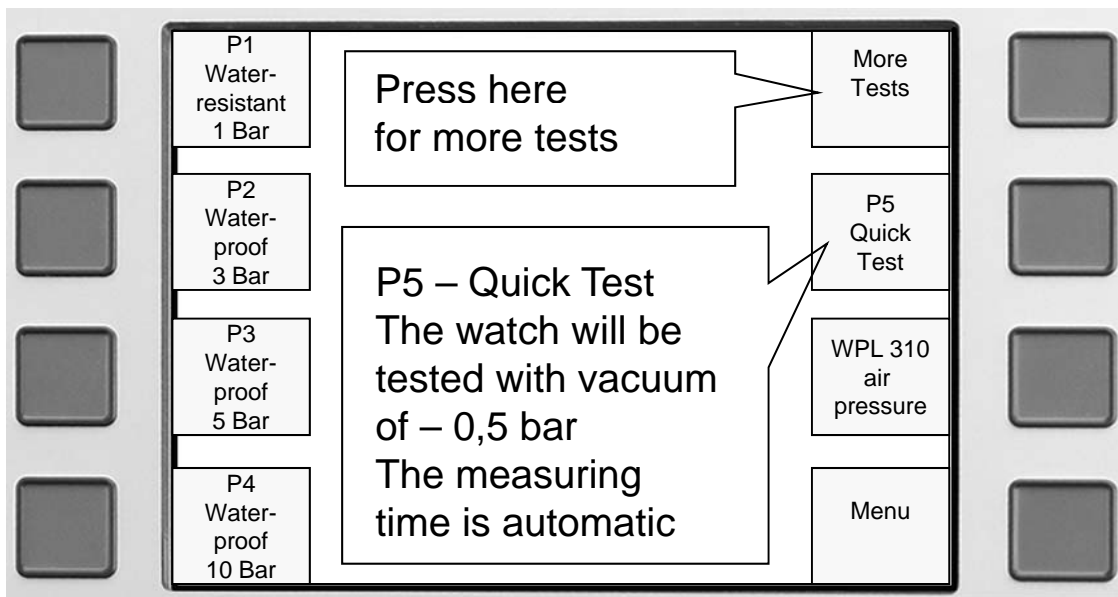

P1 = Vacuum - 0,5 bar / Pressure = 1,0 bar / Time = automatic.  
P2 = Vacuum - 0,7 bar / Pressure = 3,0 bar / Time = automatic.  
P3 = Vacuum - 0,7 bar / Pressure = 5,0 bar / Time = automatic.  
P4 = Vacuum - 0,7 bar / Pressure = 10,0 bar / Time = automatic.

### Test Procedure for P1 – P4

The watch is first tested under vacuum. The required measuring time for a precise conclusion is programmed for automatic. It is determined automatically by the device through the behavior of the watch during the measurement.

If the watch does not pass this test, the test under pressure will not be performed and the result is « Test 1 not passed ».

If the watch has passed the test under vacuum, the result is « Test 1 passed ». The test under pressure will then follow automatically. The test is started only after the housing of the watch has stabilized, which means when the housing has regained its original form.

The required measuring time for a precise conclusion is programmed for automatic. It is determined automatically by the device through the behavior of the watch during measurement.

If the watch does not pass this test, the result is « Test not passed ». If the watch passes this test, the result is « Test passed ».

## Functions of the Programmed Tests P6, P7, P8, P9

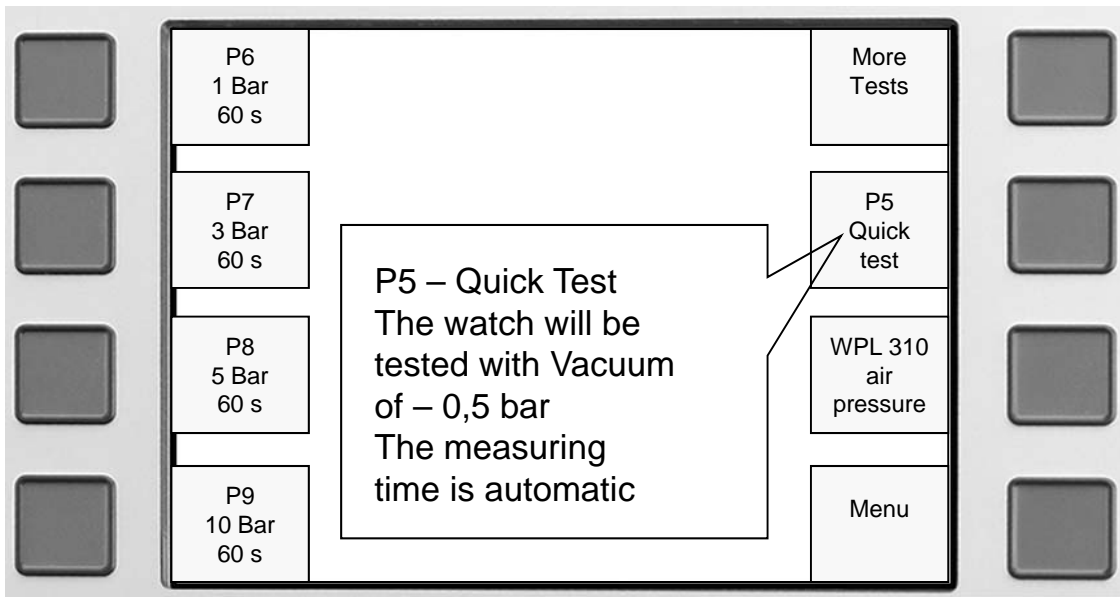

P6 = Pressure = 1,0 bar / Measuring time = 60 seconds

P7 = Pressure = 3,0 bar / Measuring time = 60 seconds

P8 = Pressure = 5,0 bar / Measuring time = 60 seconds

P9 = Pressure = 10,0 bar / Measuring time = 60 seconds

### Test procedure for P6-P9

The watch is tested with the vacuum displayed. The measuring time is programmed for 60 seconds.

If the watch does not pass this test, the result is « Test not passed ».

If the watch passes this test, the result is « Test passed ».

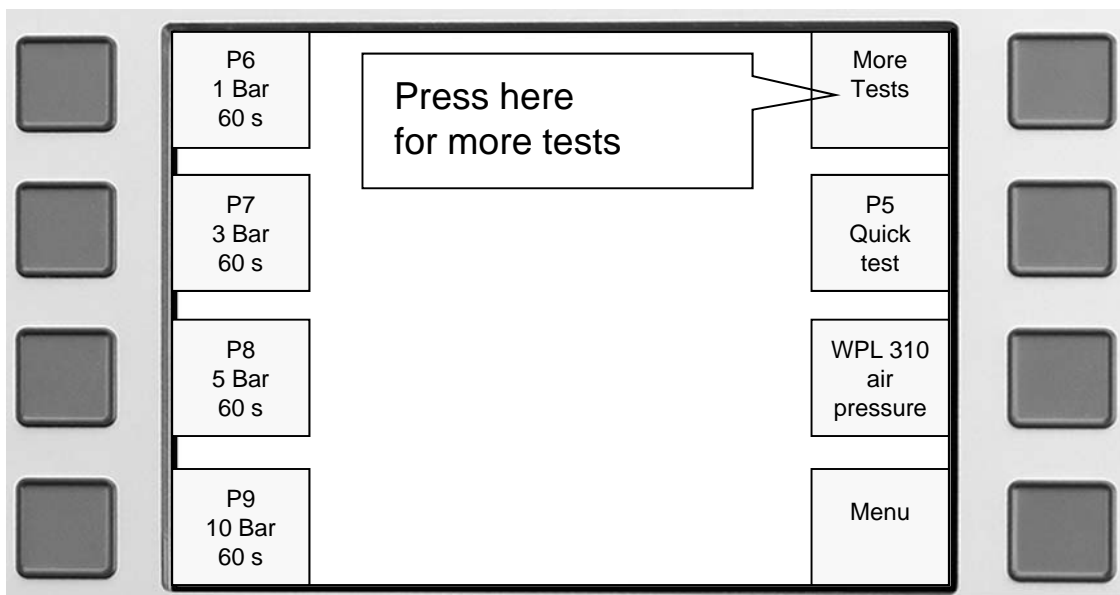

## Test procedure of the Programmed Tests P10, P11, P12

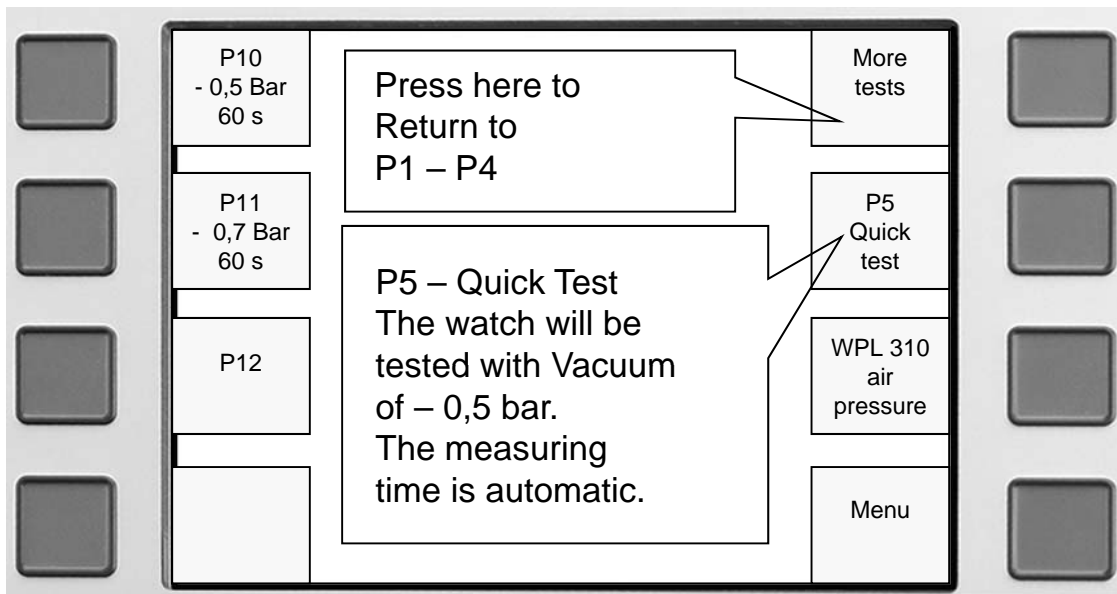

P10 = Vacuum – 0,5 bar / Measuring time = 60 seconds

P11 = Vacuum – 0,7 bar / Measuring time = 60 seconds

P12 = Not programmed

### Test procedure for P10 + P11

The watch is tested with the vacuum displayed. The measuring time is programmed for 60 seconds. If the watch does not pass this test, the result is « Test not passed ». If the watch passes this test, the result is « Test passed ».

### Prepare your own test programs

Read how you can prepare your own test program on page 15 and how you can give your test program its own name on page 16.

If you again want to install the test values pre-programmed by the factory, proceed as follows:

- Press **(Menu)**, then **(Change program)**
- Press **(Change program)** again
- Select the desired Programm.
- Now press **(Factory settings)** and **(Save)**.
- The original values are installed again.



# Change Program

1. Press « Menu »

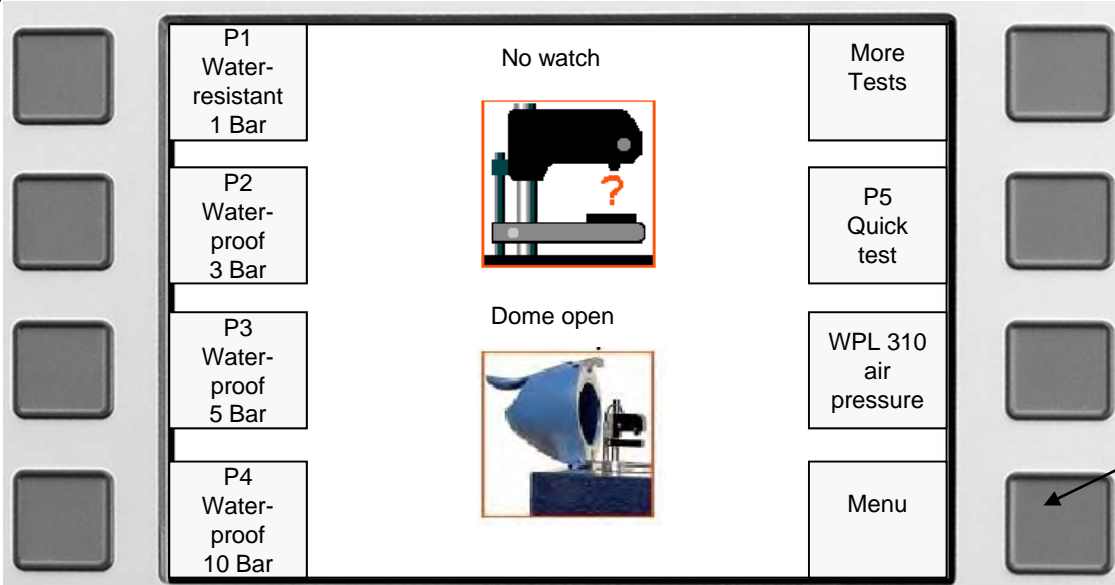

2. Press « System »

3. « Change Program »

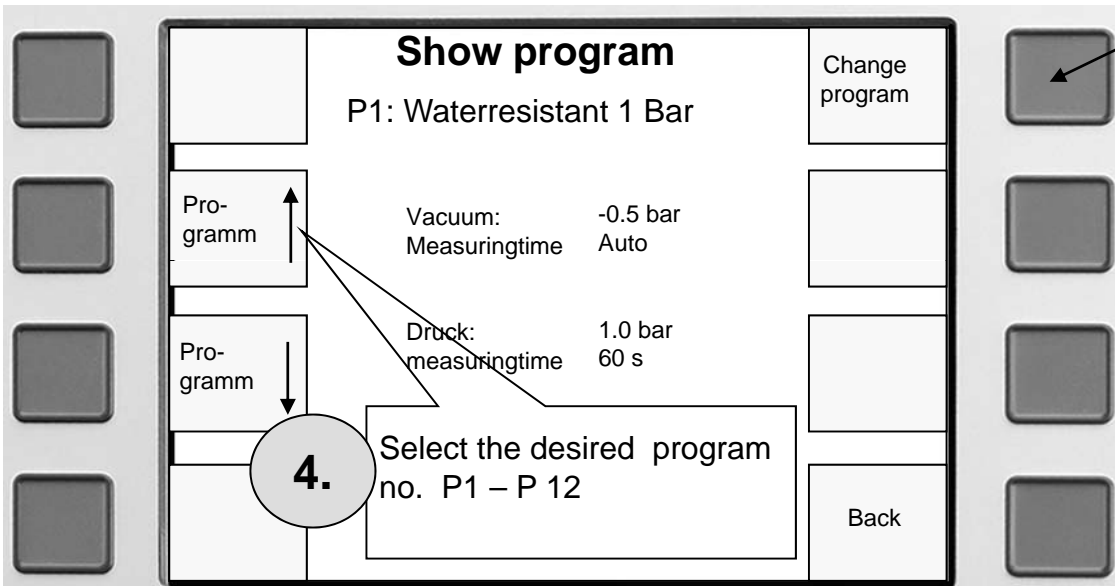

« Name of Program »

« Save Program »

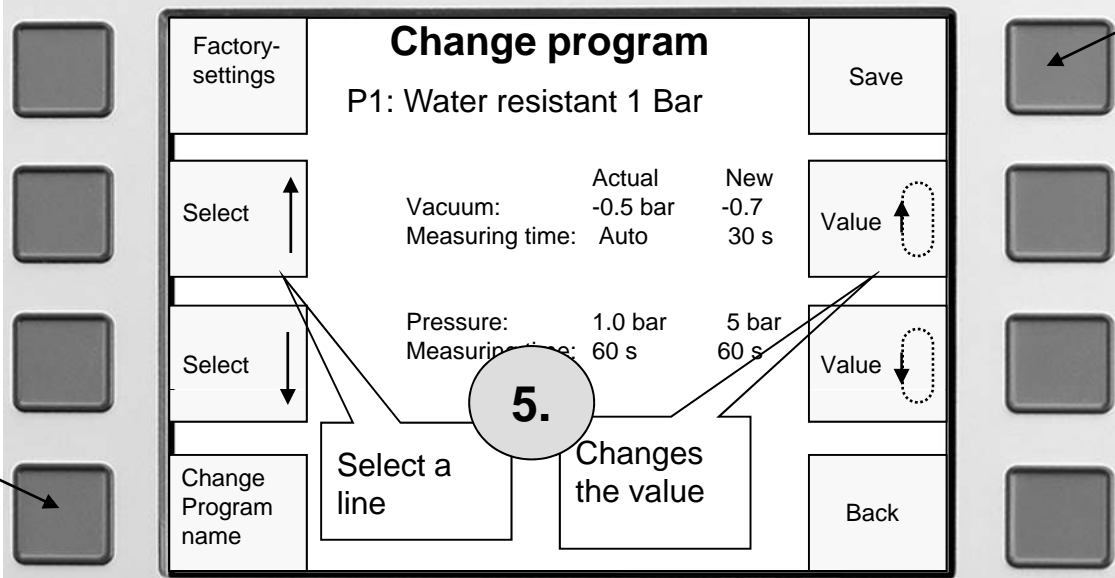

7.

# Change Program Name

You can prepare your own test programs and provide these programs with their own names.

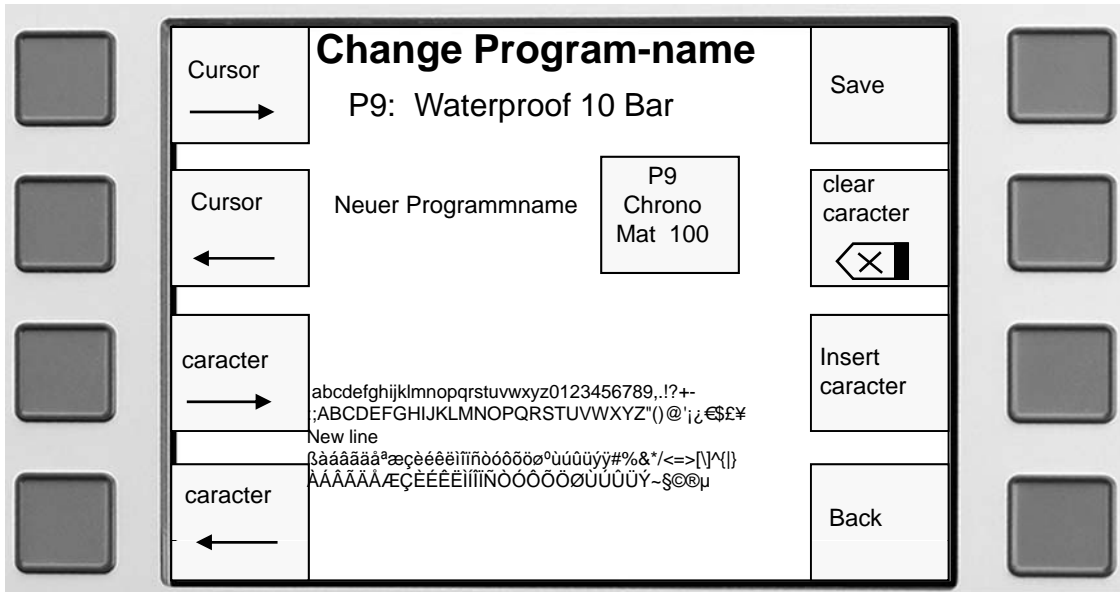

How to proceed:

Use the « **Cursor** » to move to the desired position. right or left.

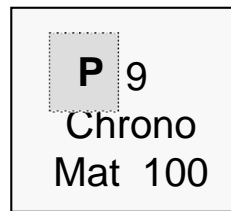

Use « **Character** » to move to the desired character. Right or left.

abcdefghijklmnopqrstuvwxyz0123456789,!?+  
 ;:ABCDEFGHIJKLMNPOQRSTUVWXYZ"()@'ı¿€\$£¥  
 New line  
 ßàáâãäåªæçèéêëìíîñóôõöø°ùúûüýÿ#%&\*/<=>[\^|}  
 ÀÁÂÃÄÅÆÇÈÉÊËÌÍÎÏÑÒÓÔÕÖØÙÚÛÜÝ~\$©®µ

Use « **Delete character** » to delete the character to the left of the cursor. In this case, it is the **9**.

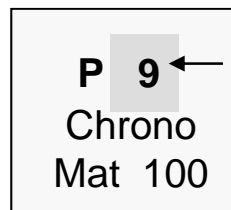

Use « **Insert character** » to free 1 place to the left of the cursor for a character. In this case, it is to the left of **n**.

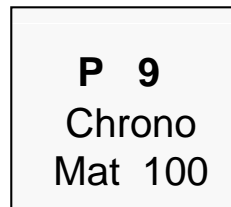

Use « **Save** » to save the program name.

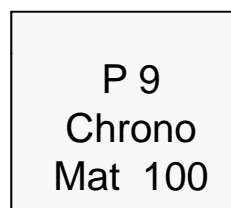

## Edit Record Head for Printout

A record of the measurement can be printed out after every measurement, if required. The record (Certificate) is structured as follows.

<pre> ***** <b>POSEIDON LT-100</b> <b>P3: Water proof 5 Bar</b> ***** Greiner vibrograf AG Mittelstrasse 2 CH-4900 Langenthal Tel. 0041 62 923 44 33 Fax: 0041 62 923 18 46 <a href="http://www.greiner vibrograf.com">www.greiner vibrograf.com</a>  25.04.2004      Nominal   Current Vacuum:         -0.5 bar -0.5 bar Measuring time: Auto       35 s Max.compression:      2.2 µm Decompression:      -0.1 µm <b>Test 1 passed</b>  Pressure:       3.0 bar   3.0 bar Measuring time: 60 s     60 s Max.compression: -32 µm DFecompression: 0.1 µm <b>Test 2 passed</b>                 </pre>	<div style="margin-bottom: 20px;"> <p>Name of instrument Testing program (will be printed allways)</p> </div> <div style="margin-bottom: 20px;"> <p>Record head: contains max. 6 lines max. 42 characters per line</p> </div> <div> <p>Test protocol (will be printed allways)</p> </div>
---	---

To input the text in the measurement record head, proceed in the same way as to change the program name (see page 16).

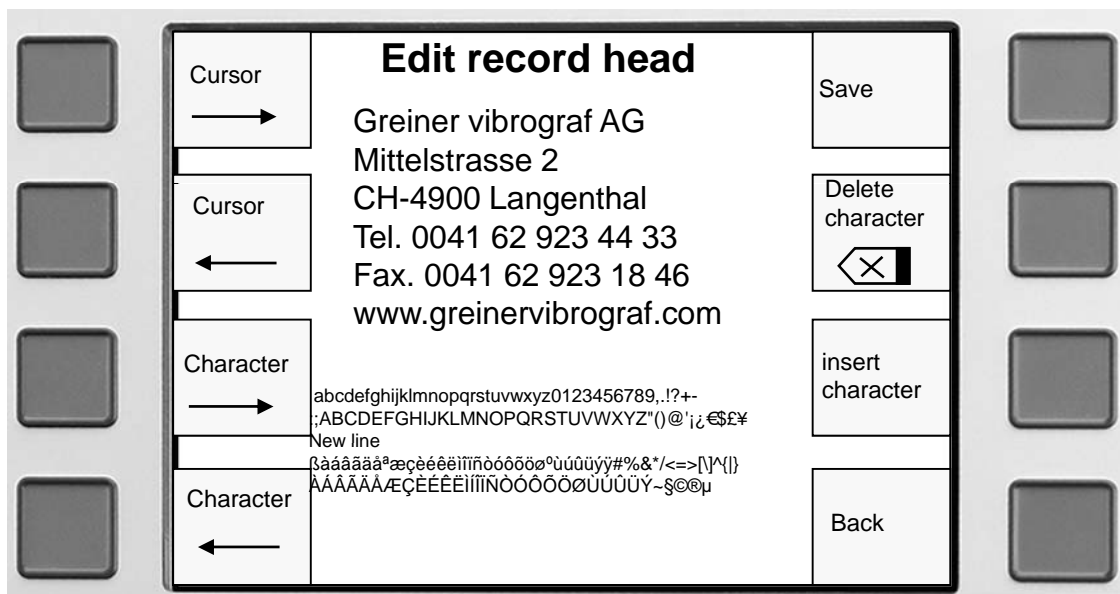

# Printer Configuration

The link cable contains on one side a D-plug 9 pins (female) and on the other end a D-plug 25 pins (male).

Link cable between Poseidon and Printer  
 Typ: D-SUB 9/25  
 DB9 female / DB25 male / 1.8m

RS-232, asynchron  
 9600 Baud  
 8 Datenbits  
 Parity None

Following connections must exist as a minimum.

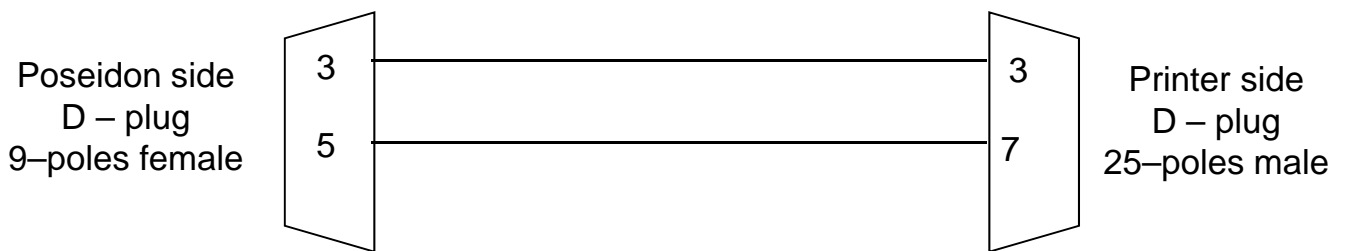

## Citizen idp 460

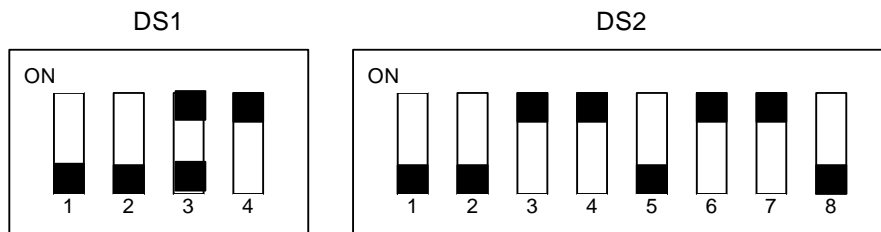

**If the characters look like this**  
 change the position of the micro switch.  
 Normally leave it in the position as delivered.

## Citizen CBM-910

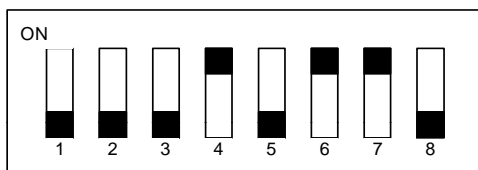

## Citizen CBM-910 II

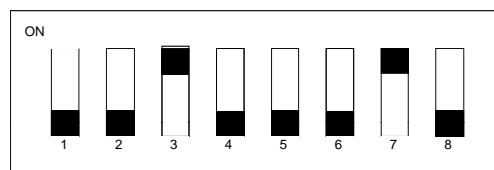

## Citizen iDP-562

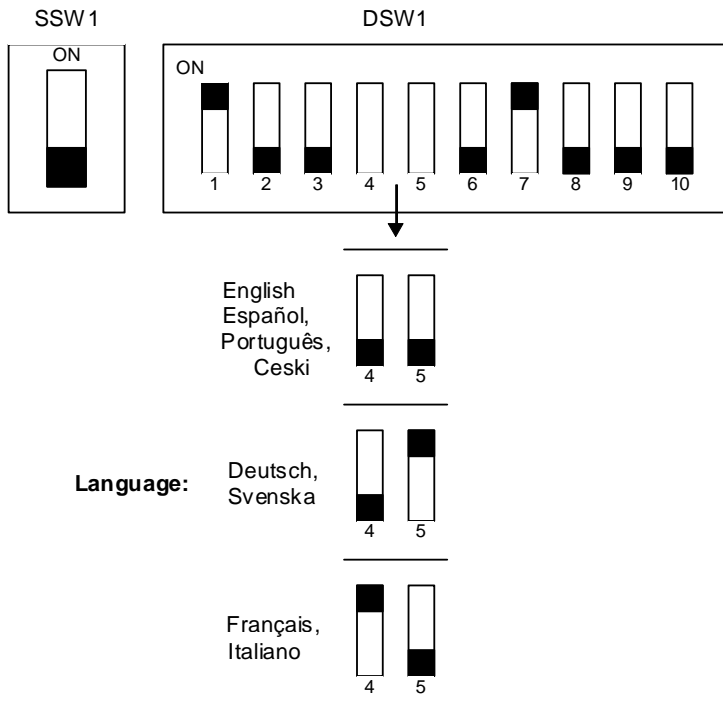

## Citizen iDP-3535

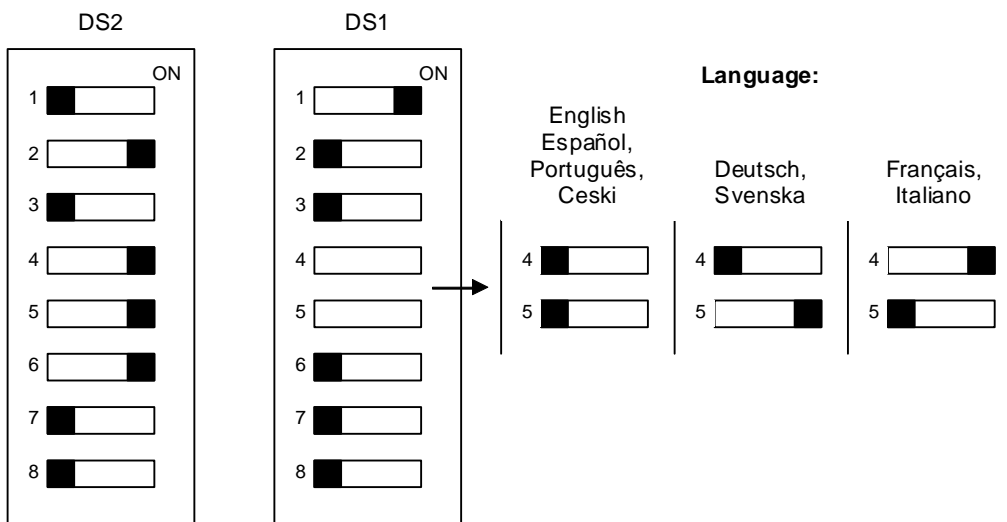

## Citizen CT-S280

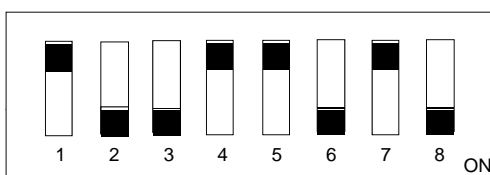

## Adjustment of the Setting Ring

When lowering the measurement head onto the watch, press the plate against the measuring head.

As a result, the setting ring moves downwards and limits the lowering of the measuring head onto the watch.

When the plate is released, the measuring head is blocked in the position and the setting ring goes upwards.

The sensor pin is now free on the watch. The green display lights up.

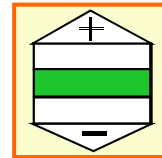
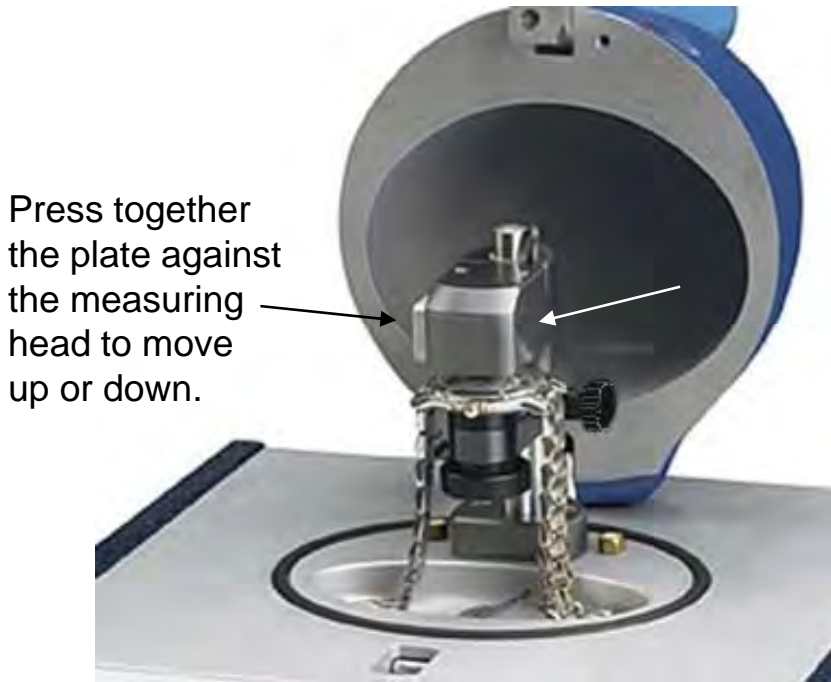

The sensor pin is in the correct Range.

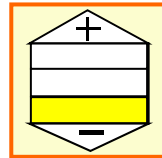
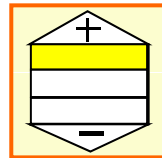

If one of the following pictures appears, you should correct the Setting ring.

For adjustment of the setting ring press:  
« Menu » ( see next page )

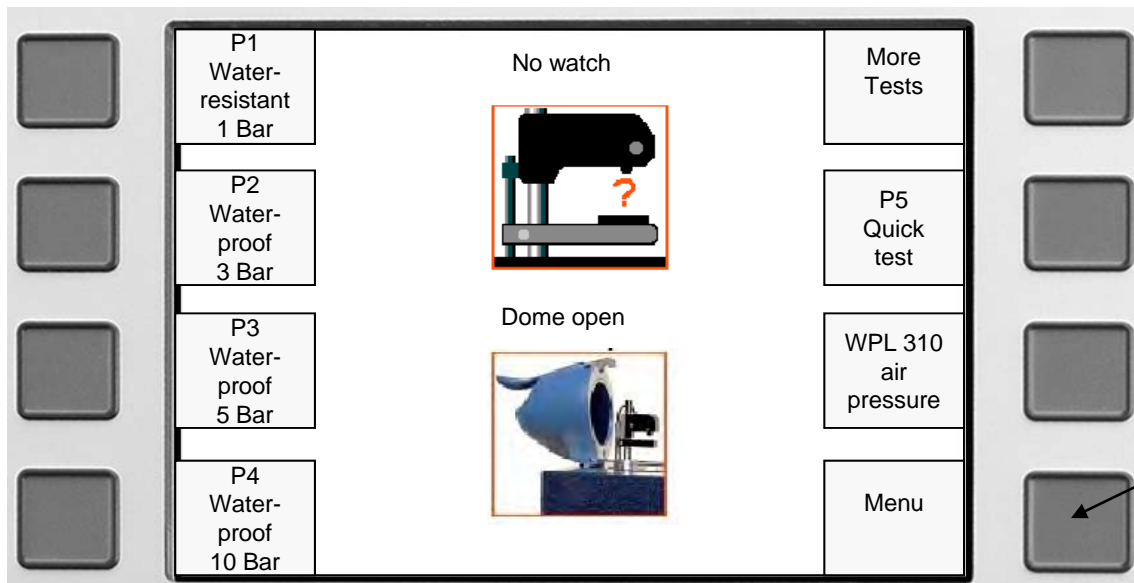

## Adjustment of the Setting Ring

Press « Adjust measuring head »

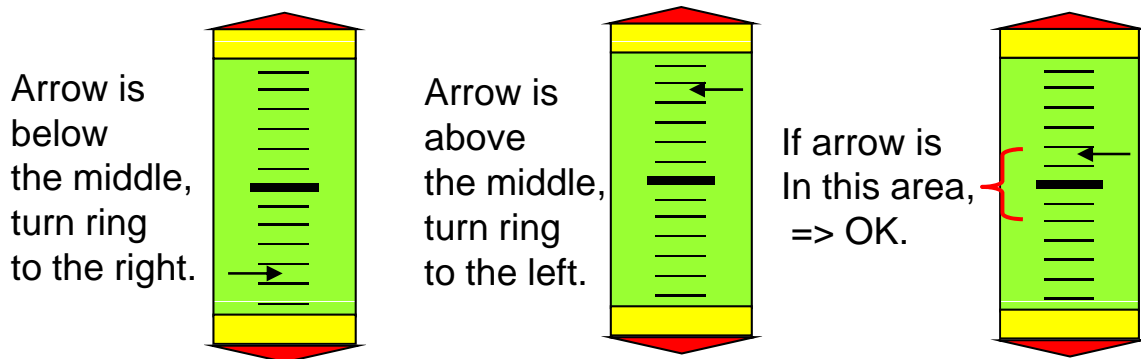
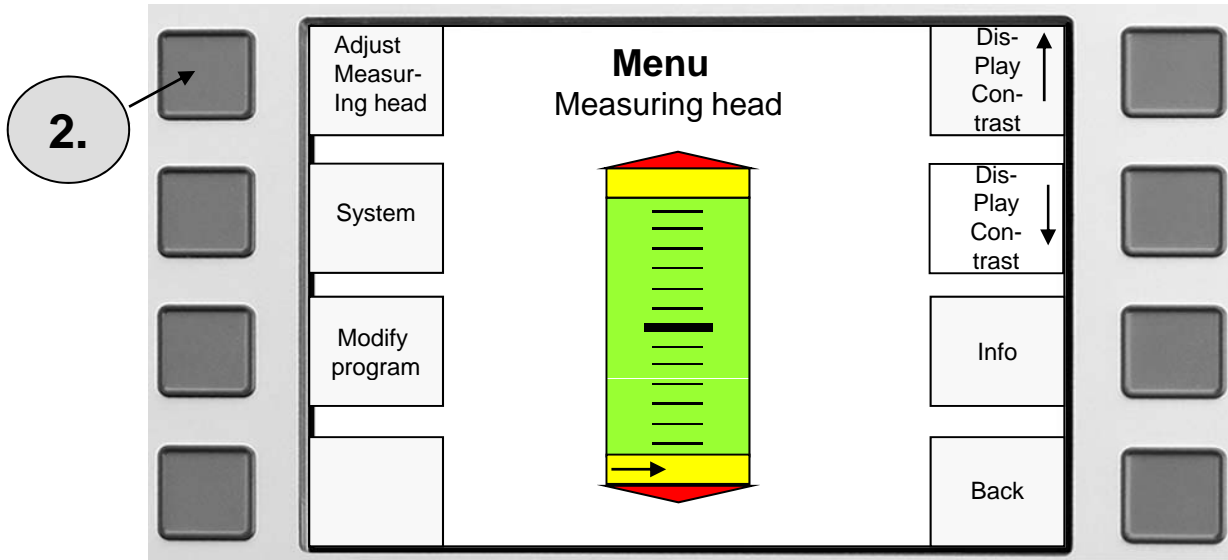

## Adjustment of the Setting Ring

First drive the measuring head upwards. Turn the ring and put sensor again on the watch. Repeat this procedure until arrow is at the right position.

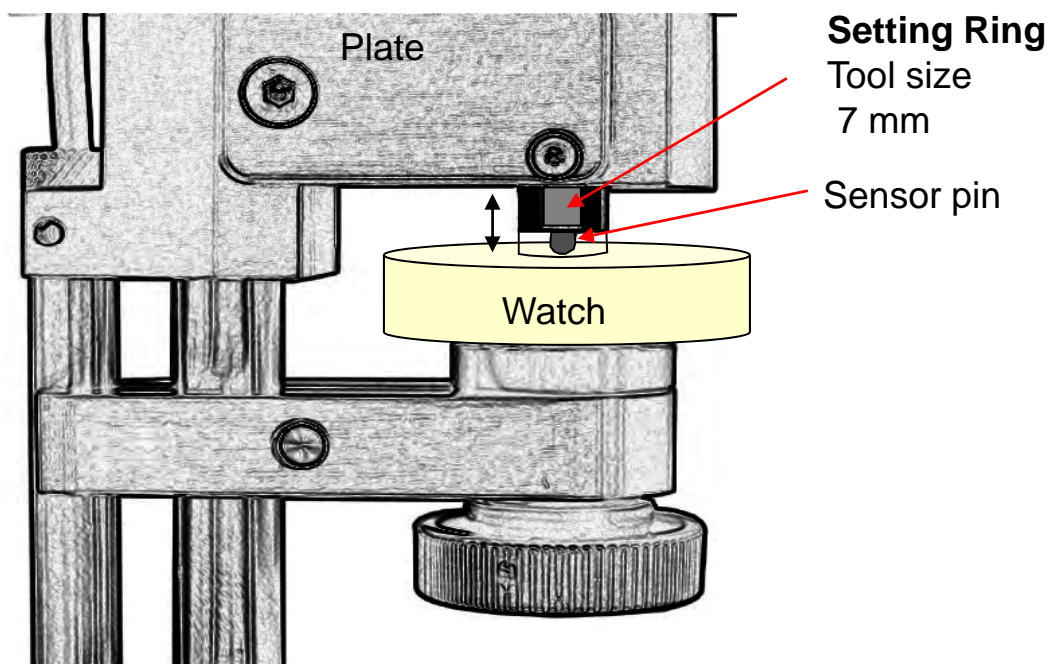



## General

The deformation of the watch is measured continuously during a tightness test by the high precision mechanics, the high resolution state-of-the-art electronics and the intelligent software. This is done with an accuracy of less than 0.0001 mm.

## Tightness test under vacuum

A vacuum is established in the chamber up to -0.7 bar.

This means that the pressure in the sealed watch is greater than the ambient pressure. The watch expands outwards. This expansion (deformation) is measured continuously through the precise displacement sensor in the measuring head. The program, which is very extensive and is based on years of experience, will now decide independently

- a) whether or not the watch was deformed sufficiently during the build-up of the vacuum.
- b) the time after which the measurement can be ended (only if the measurement time is programmed on automatic).
- c) whether the watch can be classified as tight or not tight.
- d) that the vacuum is checked continuously during the measurement operation.

If the watch is found to be not tight during the vacuum test, the test with pressure will not be performed automatically.

If required, you can perform a new test under pressure.

## Vacuum set up

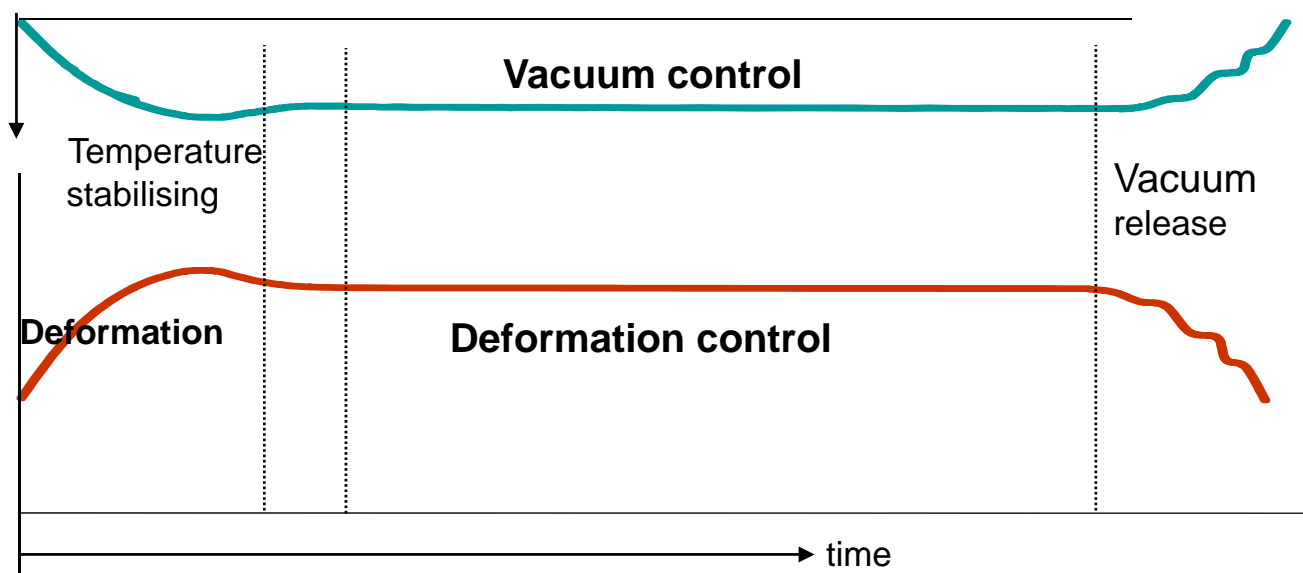

# Functioning of the Tightness Test under Pressure

## General

The deformation of the watch is measured continuously during a tightness test through the high precision mechanics, the high resolution state-of-the-art electronics and the intelligent software. This is done with an accuracy of less than  $0.0001 \mu\text{m}$ .

## Tightness Test Under Pressure

Pressure is established in the chamber up to + 10 bar.

This means that the pressure in the sealed watch is less than the ambient pressure. The watch is pressed together. This deformation is now measured continuously through the precise displacement sensor in the measuring head. The program, which is very extensive and is based on years of experience, will now decide independently

- a) whether or not the watch was deformed sufficiently during the build up of the pressure.
- b) the time after which the measurement can be ended (only if the measurement time is programmed on automatic).
- c) whether or not the watch can be classified as tight or not tight.
- d) That the chamber pressure is checked continuously during the measurement operation.

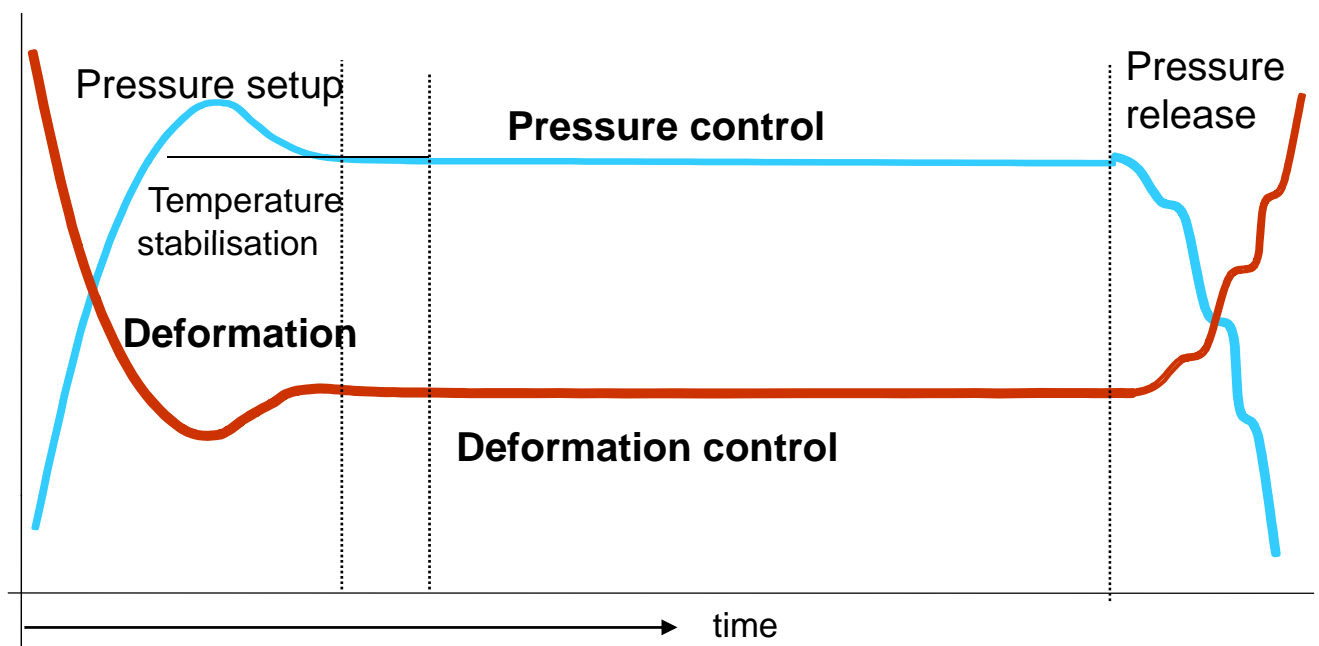

# How to Open the Poseidon

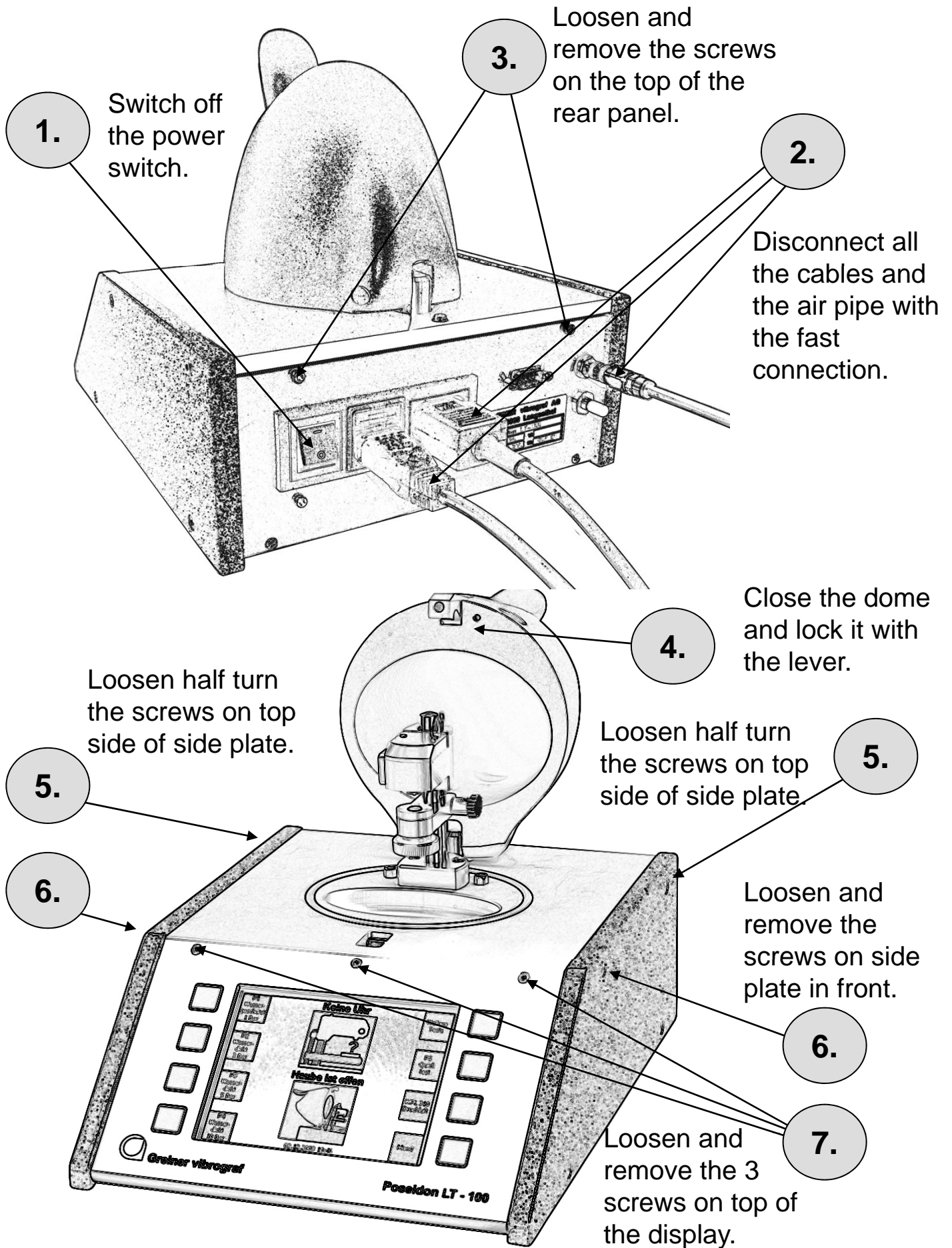

## Poseidon is now open like a flower

### ***Important:***

***Before you turn the main plate in a vertical position, close the dome and lock it with the lever. Otherwise the backside of the dome will touch the rear plate of the instrument and it can remove a part of the painting.***

If the Poseidon is opened like this, you have access of all modules.

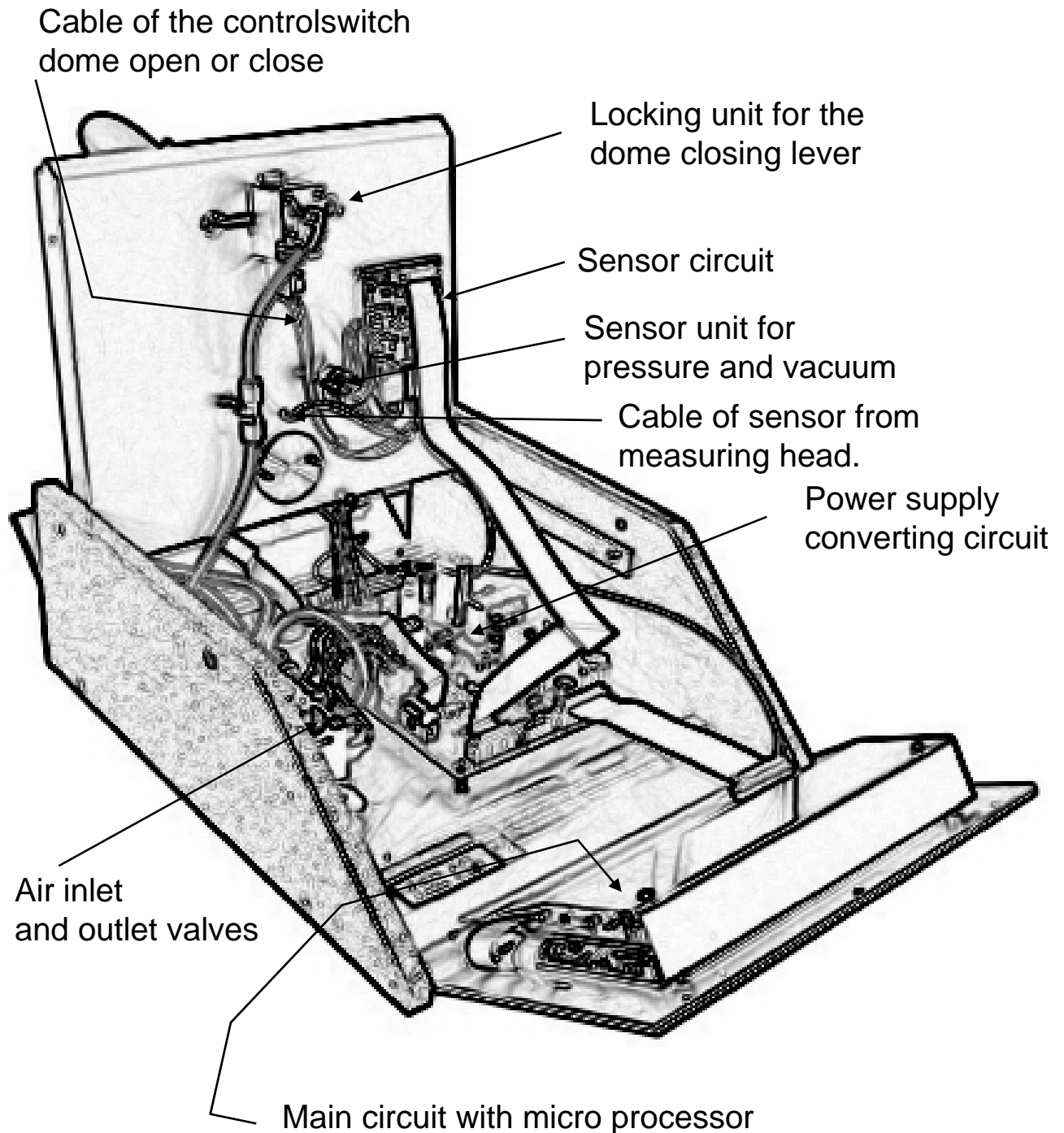

## General Information

### Included in delivery:

- 3 m of air pressure hose Ø 4 – 6 mm with fitting G 1 / 8 for compressor.
- Power connector for compressor.
- User manual.

### Maintenance:

For cleaning: use a cloth with a soft detergent.

**Don't use a sharp cleaning solution.**

From time to time, clean the sealing ring on the main plate and the surface beyond the dome.

If necessary clean the keyboard and the display.



### Important:

Please consider our specification for service unit on **page 3**.

### CE Conformity

The Poseidon corresponds with the following CE directives and rules:

89/392/EWG	machinery
EN 292 – 1991	
89/336/EWG	EMV
EN 50082-2	disturbing security Industry
EN 55011-1991	disturbing emission
23/73/EWG	Low voltage directives
EN 61010 – 1993	Electrical security